

# DANISH HANDICAP

**The National Rating Rule of the Danish Sailing Association**

**Version 2004**



DANISH SAILING ASSOCIATION

# Danish Handicap

## Contents

<b>1.0 Preface</b> . . . . .	<b>3</b>	4.2.6 Rig Type, Sloop/Bermuda . . . . .	20
1.1 Background . . . . .	3	4.2.7 Mast Factor, MF . . . . .	20
1.2 Improvements . . . . .	4	4.3 Propeller Type, PF . . . . .	20
1.3 Purpose . . . . .	4	4.4 Hiking Straps, HF . . . . .	21
1.4 Time Allowance . . . . .	4	4.5 Keel . . . . .	21
1.5 Responsibility . . . . .	4	4.5.1 Keel Weight, K . . . . .	21
1.6 Interpretation . . . . .	5	4.5.2 Keel Chord, KC . . . . .	22
1.7 Safety at Sea . . . . .	5	4.5.3 Keel Factor, KF . . . . .	23
1.7.1 Responsibility . . . . .	5	4.6 Displacement, D . . . . .	23
1.7.2 Safety . . . . .	5	4.7 Measurement Trim . . . . .	24
<b>2.0 Conventions</b> . . . . .	<b>5</b>	<b>5.0 Measurement Procedure</b> . . . . .	<b>25</b>
2.1 Arithmetic within the Rule . . . . .	5	5.1 Measurement Procedures . . . . .	25
2.2 Index of Symbols . . . . .	6	5.2 Measurers . . . . .	25
2.3 Units of Measurement . . . . .	8	5.2.1 Measurer's Equipment . . . . .	25
<b>3.0 General Regulations</b> . . . . .	<b>8</b>	5.2.2 Measurer's Task and Restrictions . . . . .	25
3.1 Race Regulations . . . . .	8	5.3 Rating Certificate and Standardising of Measurement Data . . . . .	26
3.2 Stability Screening, SV . . . . .	9	5.3.1 DH Rating/Measurement . . . . .	26
3.3 Hull Wings . . . . .	10	Certificate . . . . .	26
3.4 Permitted Materials and Construction . . . . .	10	5.3.2 Issue of DH Rating Certificate . . . . .	26
3.4.1 Permitted Materials . . . . .	10	5.3.3 One-Design Classes with Closed Class Rules . . . . .	26
3.4.2 Permitted Construction . . . . .	11	5.3.4 One-Design Classes with Open Class Rules . . . . .	27
3.4.3 Prior Approval . . . . .	11	5.3.5 Standard Hulls . . . . .	27
<b>4.0 Measurement and Calculation</b> <b>11</b>		5.3.6 Other Boats . . . . .	28
4.1 Hull Measurement . . . . .	11	5.3.7 Alteration after Measurement . . . . .	28
4.1.1 Rated Length, L . . . . .	11	5.3.8 Measurement Control . . . . .	28
4.1.2 Beam Waterline, B . . . . .	13	5.3.9 Rating Certificate on Change of Ownership or Club . . . . .	28
4.1.3 Under Water Hull Chain Girth, G 14		<b>6.0 Race Management.</b> . . . . .	<b>29</b>
4.1.4 Freeboards Fore and Aft, STF and AF . . . . .	14	6.1 Choosing Time Allowance . . . . .	29
4.2 Sail and Rig Measurement . . . . .	15	6.2 Dividing Boats into Classes . . . . .	29
4.2.1 Total Sail Area, S . . . . .	15	6.3 Scoring . . . . .	30
4.2.2 Main Sail Area, SSA . . . . .	15	6.4 Pursuit Race . . . . .	30
4.2.3 Head Sail Area, FA . . . . .	16		
4.2.4 Area of Symmetric and Asymmetric Spinnaker, SA . . . . .	18		
4.2.5 Sail Certification Mark . . . . .	20		

# Danish Handicap

## 1.0 Preface

### 1.1 Background

The present Danish Handicap Rule (DH) was developed from earlier rules, some dating back to the end of the 19th century, like:

- |                                 |      |
|---------------------------------|------|
| ● The Copenhagen Rule           | 1893 |
| ● The National Length Rule (NL) | 1913 |
| ● The Nordic Length Rule (NL)   | 1927 |
| ● The Scandicap Rule (SC)       | 1973 |
| ● The Danish Handicap Rule (DH) | 1984 |

DH is a rating rule, which can predict the handicaps of sailing boats, i.e. the speed a boat can be expected to achieve. The speed or the time allowance is stated in sec/nautical mile. Race results are calculated in accordance with the principles of “Time on Distance”.

Today DH is a VPP-based rating rule. A VPP-program (Velocity Prediction Programme) is a comprehensive programme that predicts the speed of sailing boats in numerous combinations of spreads of canvas, wind speed and course. Generally, the VPP-based rating rule is recognised to accomplish more accurate speed predictions and has an entirely different and more complex mathematical structure than former rating rules.

The rating rules before 2000 were mainly mathematical approximations of the elapsed times gained by experience. VPP-based models calculate the time allowances that sailing boats can achieve when raced optimally in all respects. This of course is not quite achievable due to variation of helm, turns, dead wind etc.

When calculating time allowances this edition of DH considers the following conditions:

- Aerodynamic model, accounting for the driving and heeling forces generated from the sails used on the various sailed courses and further the ability to flatten or reef the sails as required at the wind speed 6 m/s. Moreover, accounting for the relationship between wind speed and mast height, wind resistance of rig and hull and any use of wing mast.
- Hydrodynamic model, including all commonly known elements of hull resistance derived from the various types of hulls, keels, rudders and propeller installations and the increased resistance caused by the crew weight.
- Stability, i.e. the ability of the boat to carry its sails on the various sailed courses at the wind speed 6 m/s. And further, accounting for the effect of placing the crew in the optimal position, including any hiking straps, hull wings, and rig weight and water ballast.

The established website - [www.websejler.dk](http://www.websejler.dk) - shall be regarded as part of this rule. “Websejler” provides the possibility to see variation of time allowances for different measurement data.

DH is a development project carried out by the Technical Committee (TC) of the Danish Sailing Association.

# Danish Handicap

---

## 1.2 Improvements

The version 2004 update had focused on the following main subjects:

- State time allowances with and without spinnaker
- Better modelling of relative strength between boats with and without spinnaker
- Better modelling of relative strength between boats with jib and genoa
- More exact estimate of resistance of hull, keel and rudder
- Allow forestay at stem or on bowsprit which may be removed when the sail is lowered
- Remove "penalty" for use of asymmetric spinnaker in relation to symmetric spinnaker
- Allow water ballast and wing mast
- Allow carbon fibres in hull, deck, joiner work, keel "deadwood piece" and keel fins without "penalty"
- Remove "penalty" for use of carbon fibres in masts
- Better calculation of heeling stability caused by the crew
- Include wind resistance of rig and hull

## 1.3 Purpose

The purpose of the DH is to:

- Serve the majority of cruise/racer sailors
- Make yacht racing possible amongst yachts of different designs and sizes
- Serve the needs of local club racing as well as large regattas

## 1.4 Time Allowances

From relatively few measured data DH predicts boat speed at different courses at the wind speed 6 metres/sec [m/s] (12 knots). These boat speeds are combined into the following different Time Allowances (TA):

TA	General TA, Time Allowance
TANS	Identical to TA, but without spinnaker, Time Allowance Non-Spinnaker
TAUD	Windward-Leeward Course, Time Allowance Up-Down
TANSUD	Identical to TAUD, but without spinnaker, Time Allowance Up-Down Non-Spinnaker

The TAs are stated on the DH rating certificate.

The TA's for One-Design Classes with measurement certificate can be seen on [www.websejler.dk](http://www.websejler.dk).

Please see paragraph 6.1 also.

## 1.5 Responsibility

DSA and clubs disclaim any financial responsibility concerning the issuing of rating/measurement certificates and any errors or neglect caused by the TC of DSA or measurers.

# Danish Handicap

## 1.6 Interpretation

TC shall interpret any question concerning the DH rule and details of measurement methods. Such request for interpretation is addressed to the Chief Measurer of DSA, who shall submit the question to TC for assessment and decision. Decisions and any granted dispensation shall be considered an addendum to the rule and added to the DH rule at its next revision.

## 1.7 Safety at Sea

### 1.7.1 Responsibility

According to current law it is the owner's/skipper's responsibility to ensure the safety of the boat and her crew and further keep her seaworthy and maintain the safety equipment in compliance with the sailing instructions, class rules, ISAF Equipment Rules of Sailing (ERS) and ISAF Racing Rules of Sailing (RRS).

### 1.7.2 Safety

Considering the type and length of the race, the organiser shall decide if the safety requirements of the current Class Rules, ERS and RRS should be extended.

## 2.0 Conventions

### 2.1 Arithmetic within the Rule

The formulas within DH are calculated hierarchically as follows:

1. Perform all exponents
2. Perform multiplication and division
3. Perform addition and subtraction
4. These operations are performed within each set of parentheses starting at the innermost
5. Finally perform equals

Numbers are shown with decimal points, thus: 2.56 and 2.0 and 0.75.

The following symbols are used:

* is multiply,	thus: $2.0 * 4.0 = 8.0$
/ is divided by,	thus: $6.0 / 3.0 = 2.0$
+ is plus,	thus: $4.0 + 4.0 = 8.0$
- is minus,	thus: $3.0 - 1.0 = 2.0$
^ is to the power of,	thus: $2.0 ^ 2.0 = 4.0$ (2 squared)
	thus: $16.0 ^ 0,5 = 4.0$ (square root of 16)
	thus: $27.0 ^ (1/3) = 3.0$ (cube root of 27)
SUM is the summary of,	thus: $SUM [(1-3)^2, (2-3)^2, (3-3)^2, (4-3)^2, (5-3)^2] = 10$
$A \geq B$ , A is not less than B	
$A > B$ , A is greater than B	

# Danish Handicap

---

$A < B$ , A is less than B

$A \leq B$ , A is not greater than B

INT (A) is the integer of A - The nearest smaller cardinal number of A,

i.e. if  $A = 6.123$ , then  $\text{INT}(6.123) = 6$

i.e. if  $A = 6.573$ , then  $\text{INT}(6.567) = 6$

Sample, solution of formulae:

If  $A = (5.0 + (8.0 / 2.0^{2.0 - 2} / (3.0 + 1.0))) * 2.0$

then  $A = (5.0 + (8.0 / 4.0 - 2.0 / 4.0)) * 2.0$

then  $A = (5.0 + 2.0 - 0.5) * 2.0$

then  $A = 6.5 * 2.0$

then  $A = 13.0$

## 2.2 Alphabetical Index of Symbols in the Rule

Explanation in *bold Italic* type is defined in ISAF's Equipment Rules of Sailing (ERS).

Symbol	Units	Explanation	Paragraph
AF	[m]	Freeboard at aft transom	4.1.4
B	[m]	Beam waterline at Bmax station	4.1.2
Bmax	[m]	Maximum beam of Hull	4.1.2
CL	[nm]	Length of Racecourse	6.3 & 6.4
CT	[s]	Corrected time	6.3
D	[t]	Displacement weight	4.6
Dcorr	[t]	D, corrected	3.2
DH	-	Danish Handicap Rule	-
Di	[t]	Displacement weight, individual	4.6
Dm	[t]	Displacement weight, average	4.6
DSA	-	Danish Sailing Association	-
d	[%]	Percentage of Dcorr	3.2
E	[m]	Maximum mainsail boom length (ERS F.12.1)	4.2.2
ET	[s]	Elapsed time	6.3
ERS	-	ISAF Equipment Rules of Sailing	-
FA1	[m <sup>2</sup> ]	Headsail area 1, max. headsail	4.2.3
FA2	[m <sup>2</sup> ]	Headsail area 2, average of 1 and 3	4.2.3
FA3	[m <sup>2</sup> ]	Headsail area 3, fore triangle	4.2.3
FBSB	[m]	Freeboard starboard at Gmax station	4.1.3
FBBB	[m]	Freeboard port at Gmax station	4.1.3
FSP	[m]	Forestay perpendicular	4.2.3
G	[m]	Hull chain girth, under water	4.1.3
Gmax	[m]	Maximum hull chain girth from sheer	4.1.3
HB	[m]	<b>Top width</b> , (mainsail) (ERS G.7.8)	4.2.2
HF	-	Hiking factor	4.4
IMS	-	International Measurement System	5.3.6
ISP	[m]	Height of spinnaker halyard above sheer	4.2.4
ISAF	-	International Sailing Federation	-
J	[m]	Max. base of fore triangle (ERS F.3.1)	4.2.3
JR	[m]	Max. permitted roach of headsail	4.2.3
K	[t]	Keel weight	4.5.1
KC	[m]	Keel chord	4.5.2
KF	-	Keel factor	4.5.3

# Danish Handicap

Symbol	Units	Explanation	Paragraph
Kcorr	[t]	Keel weight, corrected to D/3	4.5.1
L	[m]	Measured length, hull	4.1.1
LOA	[m]	Length overall, hull (ERS D.3.1)	4.1.1
LP	[m]	Max. <b>Luff perpendicular of jib</b> (ERS G.7.11)	4.2.3
LYS	-	Leading Yard Stick	-
MF	-	Mast factor	4.2.7
MGM	[m]	<b>Half width</b> (mainsail) (ERS G.7.5)	4.2.2
MGU	[m]	<b>Three-quarter width</b> (mainsail) (ERS G.7.6)	4.2.2
n	[number]	Number of weighed boats	4.6
OA	[m]	Aft overhang	4.1.1
OF	[m]	Forward Overhang	4.1.1
P	[m]	Maximum mainsail hoist	4.2.2
PF	-	Propeller Type	4.3
RRS	-	ISAF Racing Rules of Sailing	-
S	[m <sup>2</sup> ]	Sail area	4.2.1
SA	[m <sup>2</sup> ]	Spinnaker area	4.2.4
SBmax	[m]	Distance from stem to Bmax station	4.1.2
SF	[m]	<b>Foot length</b> , symmetric spinnaker (ERS G.7.1)	4.2.4
SFA	[m]	<b>Foot length</b> , asymmetric spinnaker (ERS G.7.1)	4.2.4
SFB	[m]	Rated, spinnaker foot length	4.2.4
SGmax	[m]	Distance from stem to Gmax station	4.1.3
SL	[m]	<b>Leech length</b> , symmetric spinnaker (ERS G.7.2)	4.2.4
SLB	[m]	Rated, spinnaker leech length	4.2.4
SLE	[m]	<b>Leech length</b> , asymmetric spinnaker (ERS G.7.2)	4.2.4
SLU	[m]	<b>Luff length</b> , asymmetric spinnaker (ERS G.7.3)	4.2.4
SMW	[m]	Spinnaker maximum width, symmetric spinnaker	4.2.4
SMWA	[m]	Spinnaker maximum width, asymmetric spinnaker	4.2.4
SMWB	[m]	Rated, spinnaker maximum width	4.2.4
SPL	[m]	Spinnaker pole length	4.2.4
SPLB	[m]	Rated, spinnaker pole length	4.2.4
SSA	[m <sup>2</sup> ]	Mainsail area	4.2.2
STF	[m]	Freeboard at stem	4.1.4
SV	-	Screening value for stability	3.2
TAA	[s/nm]	Chosen Time allowance for the actual boat	6.3
TA	[s/nm]	Time Allowance, General Purpose	1.4, 6.1
TANS	[s/nm]	Time Allowance Non-Spinnaker	1.4, 6.1
TANSUD	[s/nm]	Time Allowance Non-Spinnaker Up-Down	1.4, 6.1
TAUD	[s/nm]	Time Allowance Up-Down, Windward/Leeward Course	1.4, 6.1
TAS	[s/nm]	Time Allowance, scratch boat	6.3
TC	-	Technical Committee of DSA	-
Tmax	[m]	Max. <b>Luff length</b> , jib (ERS G.7.3)	4.2.3
TPS	[m]	Tack point, asymmetric spinnaker	4.2.4
UDFSB	[m]	Flare at starboard Bmax station	4.1.2
UDFBB	[m]	Flare at port Bmax station	4.1.2
UDHBmax	[m]	Hull wing width at Bmax station	4.1.2
UDHmax	[m]	Hull wing max. width	4.1.2
VCG	[m]	Vertical Centre of Gravity (keel)	4.5.3
VMG	[s/nm]	Velocity Made Good (boat speed, direct course to next mark)	6.1
W	[kg]	Heeling weight, 90 degrees heel test	3.2
Wmin	[kg]	Min. heeling weight, 90 degrees heel test	3.2

# Danish Handicap

## 2.3 Units of Measurement

- Length, metre [m] with 2 decimals
- Length of racecourse, nautical mile [nm] (1 nm = 1852 m) with 2 decimals
- Displacement weight, tons [t] (1 ton = 1000 kg) with 2 decimals
- Weight, kilograms [kg] in cardinal numbers
- Area, square metres [m<sup>2</sup>] with 2 decimals
- Volume, cubic metre [m<sup>3</sup>] with 2 decimals
- Time, seconds [s] in cardinal numbers or hours [h]
- Time allowance, seconds per nautical mile [s/nm] with 1 decimal
- Speed, knots [knot] (1 knot = 1 nm/h = 1852 m/h = 1.852 km/h)

## 3.0 General Regulations

According to item (d) of the RRS definition “Rule” the DH rule applies as class rules for all boats racing in regattas or classes organised for DH-boats.

### 3.1 Racing Regulations

1. Only mono hull keelboats with a length overall, LOA of minimum 5.50 m and maximum of 25.00 m and a minimum displacement of 0.30 tons shall be rated under DH. If these limits are exceeded the boat must have the approval of the TC before any rating certificate is issued.
2. Except in the following cases, the class rules of national or international one-design classes are substituted by the DH rule when racing under this rule:
  - a. When boats of national or international one-design classes are racing under the DH rule with their class-imposed time allowances, the class rules shall apply only to that extent to which they influence the DH measurement data used to calculate their one-design class rating.
  - b. Only when permitted by the class rules of the boat, and the time allowances are calculated accordingly, should hiking straps be used, see also part 4.4. Only then are hiking straps permitted on board the boat racing under the DH rule.
  - c. If class rules of the boat had changed RRS 50.4 the regulations of part 4.2.3 shall apply when sail area is calculated.
3. Boats may be rated with both symmetric and asymmetric spinnakers.
4. Time allowances for symmetric spinnakers are calculated as if they were set only to a spinnaker pole (SPL).
5. Time allowances for asymmetric spinnakers are calculated as if they alternately were tacked both at the bow or bowsprit (forward end of TPS) or set to a spinnaker pole (SPL).
6. Boats rated with spinnaker may instead of the spinnaker set two (2) headsails simultaneously on the same forestay. One headsail shall then be set to windward on a spinnaker pole (SPL). See as well item 3.1.10.
7. Boats rated without spinnaker may set the headsail to a pole with no length limit.
8. Except that the number of spinnakers shall be limited to two (2) (e.g. 1 symmetric and 1 asymmetric spinnaker), there shall be no limitations on the number of sails carried on board whilst racing.
9. Adjustment of standing rigging, i.e. forestay and shrouds, whilst racing is prohibited

# Danish Handicap

10. Headsails shall be set with the luff fastened to the forestay.

At least 80 % of its luff length (Tmax) shall be fasten to the forstay either by means of minimum 4 evenly distributed hanks, headfoil or similar fastening methods. The only exception is that one of the two headsails mentioned in part 3.1.6 may be set flying.

Spinnakers shall be set flying, i.e. not fastened to a forestay.

Battens are not permitted in spinnakers.

## 3.2 Stability Screening, SV

### Formula 1:

$$SV = (LOA * B_{max} * S^{0.5}) / D$$

SV shall be rounded to 2 decimals.

If  $SV \leq 70$ , then the boat's stability shall normally not be subject to further screening.

If  $SV > 70$ , then the boat's stability shall be screened according to formula 2.

### Formula 2:

$$d = 100 / ISP / D_{corr} * [((0.5 * (FBSB + FBBB) + 1 / 3 * (G^2 - B^2)^{0.5}) * K) - (0.25 * (FBSB + FBBB) * D)]$$

d shall be rounded to 1 decimal.

$$D_{corr} = [(SV / 70)^{(1/3)}] * D$$

Dcorr shall be rounded to 2 decimals.

If  $D_{corr} < D$ , then Dcorr shall be taken as D.

ISP shall not be taken as less than

$0.75 * P$  in formulae 2.

If the boat has no spinnaker halyard, then ISP shall be taken as  $0.75 * P$ .

If  $d \geq 4.0\%$ , then the boat is normally considered to have sufficient stability to race under the DH.

If  $d < 4.0\%$ , then the boat shall not be rated under the DH.

A boat may be modified and re-calculated to meet the requirement of formula 2.

Alternatively, the boat in measurement trim may be

subjected to a 90 degrees heel test

(see fig. 1), from which it shall be able to recover with a weight W attached at the upper end of ISP. At the 90 degrees heel test ISP shall not be taken as less than  $0.75 * P$ .

$W_{min} = 35 * D_{corr}$  ( $W_{min}$  shall be rounded to a cardinal number and shown on the rating certificate).

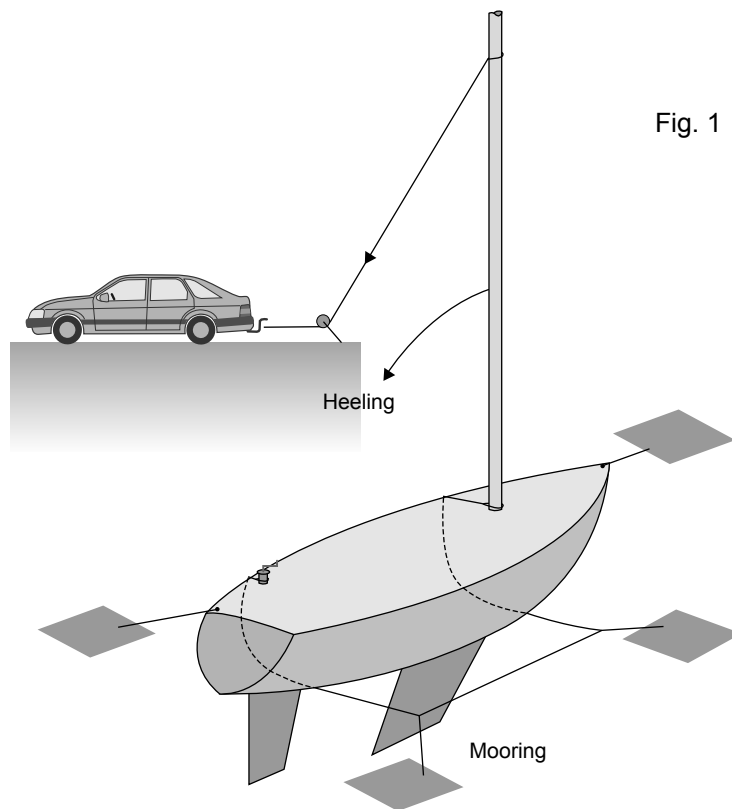
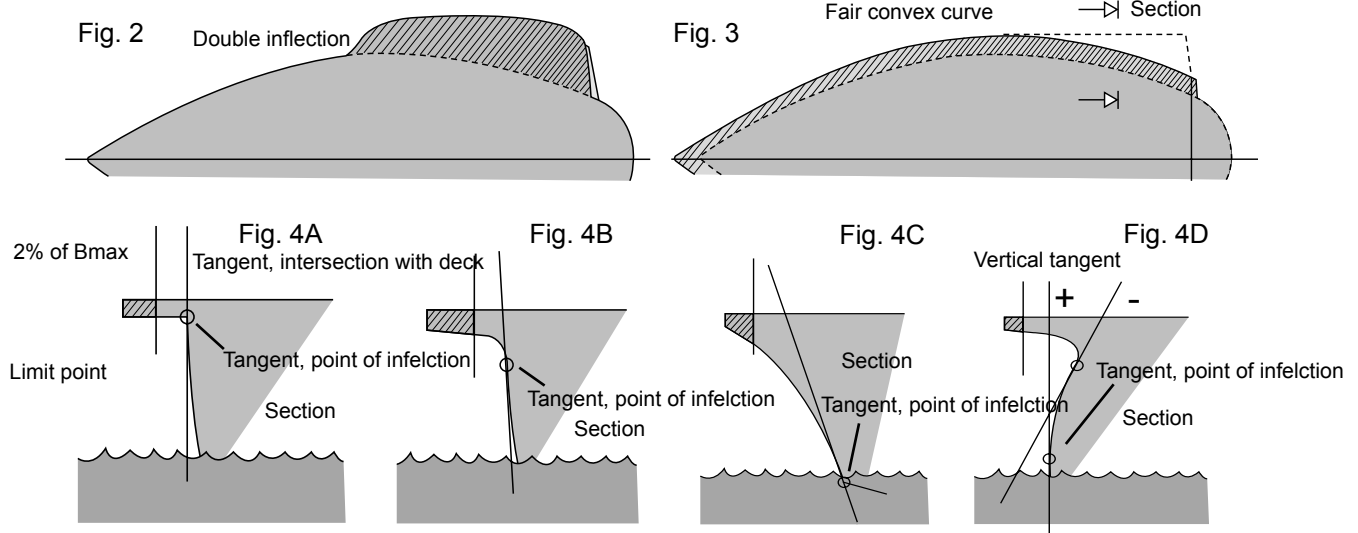

Fig. 1

# Danish Handicap



## 3.3 Hull Wings

Hull wings are permitted and defined as follows:

1. Hull wings are described in the horizontal plane as a bulge of the fair curve of the gunwale, i.e. the gunwale in the horizontal plane curves with a double inflection. (See fig. 2).
2. Even though, the gunwale in the horizontal plane describes a fair convex curve with no double inflection, a hull wing might appear at any vertical section where bent or inflected flare occurs above a level of  $(B_{max}/6)$  below the sheer. (See fig. 3).

A hull wing is defined, as that part of the boat, which extends outboard beyond the limit point described below:

1. First of all, a deck point shall be defined as the point at which the vertical tangent to the hull at its point of inflection would, if extended, cut the deck. Secondly, the limit point shall be determined, as the point, which is moved the distance of  $0.02 * B_{max}$  outboards from the deck point. (See fig. 4A, 4B, 4C)
2. Where the point of inflection is found to be above the point of maximum beam of the hull in the section, the deck point shall not be taken inboard of the point vertically above the point of maximum beam in that section. (See fig. 4D).

## 3.4 Permitted Materials and Construction

No boat shall hold or have a rating certificate issued or race under DH, if other than the following permitted materials and methods of construction are used.

### 3.4.1 Permitted Materials

- Wood, natural fibres, reinforced concrete and un-reinforced plastic
- Iron, steel, lead, copper and their alloys; bronze, brass, monel and aluminium of the 5000 and 6000 standard series
- Plastic reinforced with fibre of any of the following materials: glass, polyester, polyamide (Nylon), polyethylene, aramid (Kevlar) and natural fibre.

# Danish Handicap

---

Except that high tensile carbon may be used without correction of the time allowance as follows:

- In rudders, rudder stocks, quadrants, pedestals, wheels and tillers
- In sail battens, head boards and sail hardware (e.g. eyes, rings, slides, hanks etc.)
- In main booms, spinnaker poles, jockey poles, deck and spar fittings except winch drums, spindles and gears
- In the structure of the hull, deck and interior joiner work, keel “deadwood piece” or keel fin

High tensile carbon may be used with correction of the time allowance as follows:

- In masts (and integral mouldings, such as tangs), spreaders and jumper struts, see also paragraph 4.2.7

### **3.4.2 Permitted Construction**

If sandwich construction is used in hull skin and deck skin, only core material of wood or plastic foam shall be used. However, for boats of LOA greater than 17.00 m, in the hull and deck structure, aramid paper honeycomb core material can be used. In all boats, core materials of wood, plastic foam or other forms of non-metallic honeycomb core material can be used in internals and interior joiner work.

For any standing rigging which is not permitted to adjust while racing, the only permitted materials are steel wire and steel rod. (See also paragraph 3.1 item 9)

### **3.4.3 Prior Approval**

In order to preclude boats from being refused rating under DH by the TC, designers and boat owners planning to build new designs are recommended to have their plans with relevant information on choice of materials and necessary calculations assessed by the TC.

If a boat does not comply with all the requirements of paragraph 3, General Regulations, the boat shall be assessed by the TC. Any questions regarding this shall be referred to the DSA Chief Measurer. See also paragraph 1.6.

## **4.0 Measurement and Calculation**

### **4.1 Hull Measurement**

The flotation measurements OF, OA, UDFSB, UDFBB, FBSB, FBBB, STF and AF, stated in paragraph 4.1.1 - 4.1.4, are to be taken afloat with the boat in measurement trim shown in paragraph 4.7

#### **4.1.1 Rated Length, L**

$L = LOA - OF - OA$

LOA (ERS D.3.1) shall be the total length of the hull, including bulb, but excluding any transom hanged rudders, protruding stem fittings, pulpits or bowsprits.

# Danish Handicap

Fig. 5

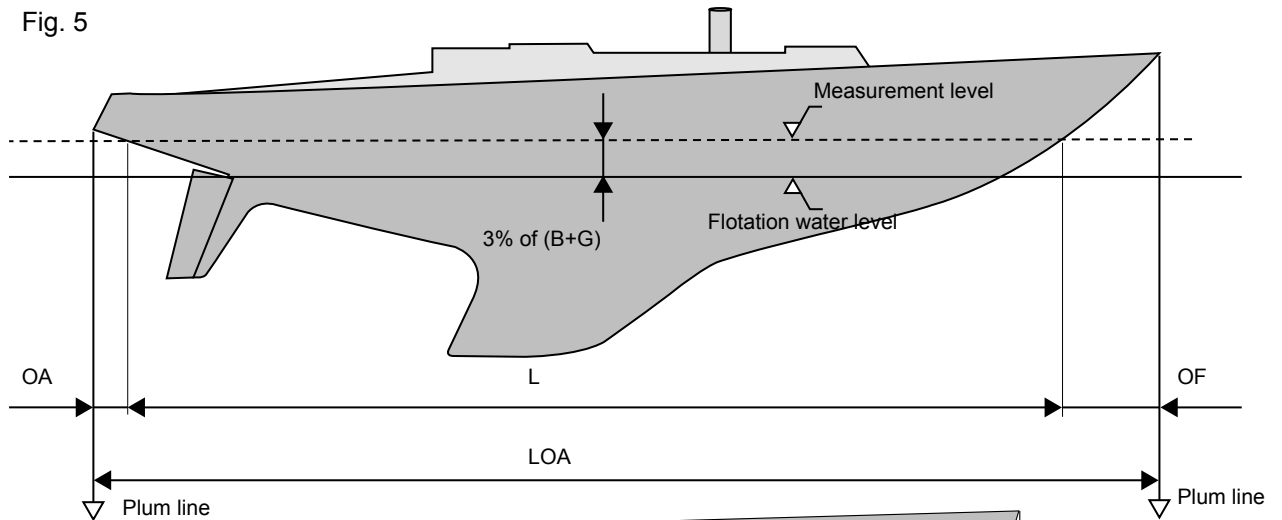

OF and OA shall be the forward and aft overhangs with the boat afloat in measurement trim. They are measured from plum lines hung at the extreme ends of LOA to the hull at stem and at stern on the centre plane of the hull at a height of  $0.03 \cdot (B+G)$  above the waterline of flotation (see fig. 5).

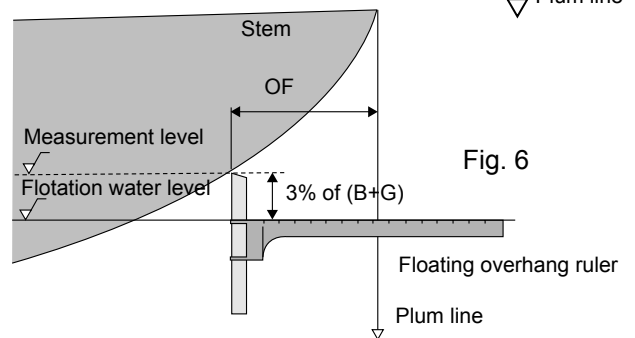
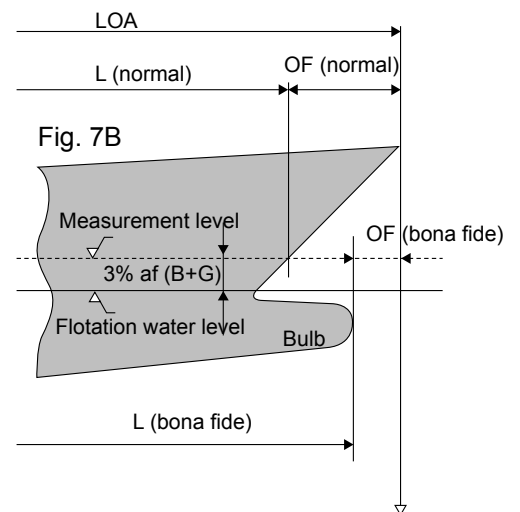
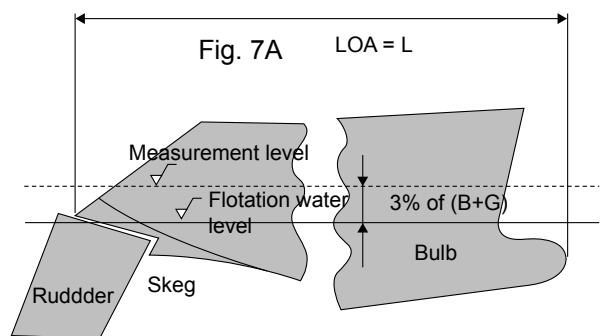

Fig. 6

A special made floating overhang ruler is used to measure the length of the overhangs. The vertical ruler of this floating overhang ruler shall be set to the correct height of  $0.03 \cdot (B + G)$  above the waterline of flotation. With the overhang ruler floating on the water it is moved into position so the upper end of its vertical ruler is just touching the forward/aft end of the hull at the centre plane. The overhang length is found at the intersection of the floating overhang ruler and the plum line (see fig. 6).



If the hull at stem or stern should have any point protruding forward or aft of the normal extreme ends of the rated length, this other protruding point shall be the bona fide end of the rated length (see fig. 7A and 7B).

A rudder shall be excluded from the rated length. Skeg at the stern shall not be ignored and OA shall be measured to the lower face or trailing edge of any skeg.

# Danish Handicap

## 4.1.2 Beam Waterline, B

$$B = B_{max} - UDFSB - UDFBB$$

$B_{max}$  shall be the maximum beam of the hull including any rubbing strakes, but excluding any “hull wings” at deck level (see paragraph 3.3), measured at a vertical transverse section at right angles to the vertical centre plane of the hull.  $SB_{max}$  shall be the distance from the  $B_{max}$ -station to the stem, measured at the vertical centre plane of the hull.

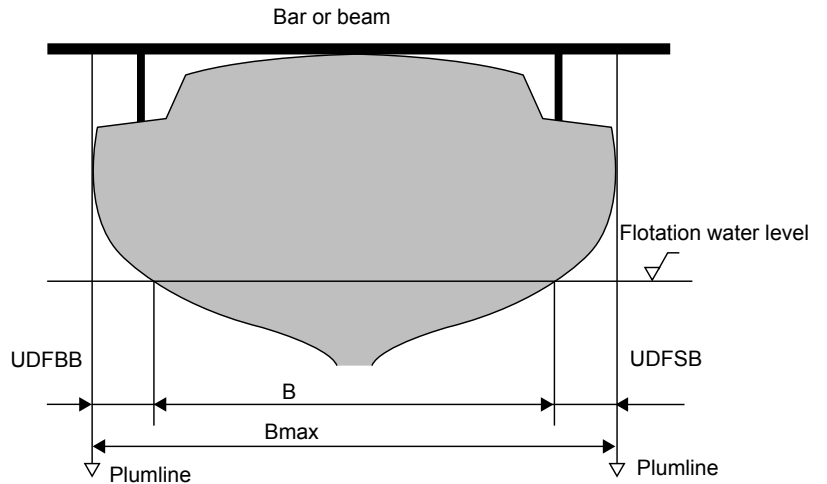

Fig. 8

UDFSB and UDFBB shall be the starboard and port flare, measured horizontally and at right angles to the centre plane from plum lines hung at the extreme ends of  $B_{max}$  to the sides of the hull level with the flotation measurement waterline at the  $B_{max}$  station ( $SB_{max}$ ) (see fig. 8). When calculating the time allowance the beam waterline,  $B$ , measured in measurement trim is corrected in order to account for the increase of sink caused by the crew weight.

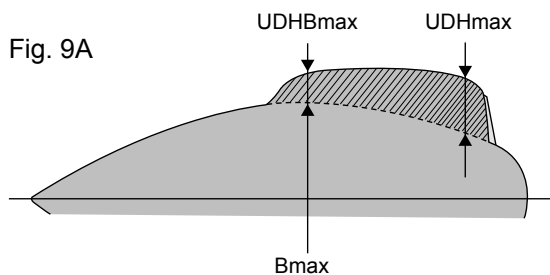

Fig. 9A

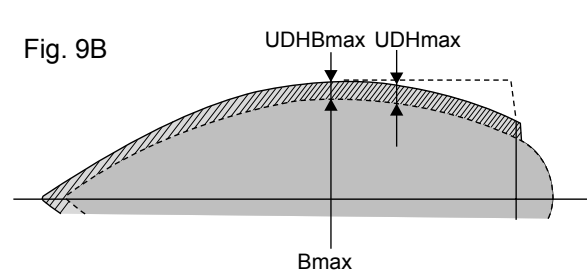

Fig. 9B

Hull wings at deck level (outrigger) are permitted.

In the case of hull wings (see paragraph 3.3)  $UDHB_{max}$  and  $UDH_{max}$  are measured.  $UDHB_{max}$  shall be the width of the hull wing at the starboard or port side of the hull at the  $B_{max}$  station ( $SB_{max}$ ), measured horizontally from the tip of the hull wing to the limit point at the deck (see paragraph 3.3) at right angles to the vertical centre plane of the hull (see fig. 9A and 9B).

$UDH_{max}$  shall be the max. width of the hull wing at the starboard or port side of the hull at any position, measured horizontally from the tip of the hull wing to the limit point at the deck (see paragraph 3.3) at right angles to the vertical centre plane of the hull (see fig. 9A and 9B).

# Danish Handicap

## 4.1.3 Under Water Hull Chain Girth, G

$$G = G_{max} - FBSB - FBBB$$

$G_{max}$  shall be the maximum chain girth of the hull.  $G_{max}$  is measured from the sheer line on the one side of the hull under the keel (including keel wings and excluding hull wings (outriggers), if any) to the sheer line on the other side at a transverse section at right angles to the centre plane of the hull (see fig. 10 and 11A-G).

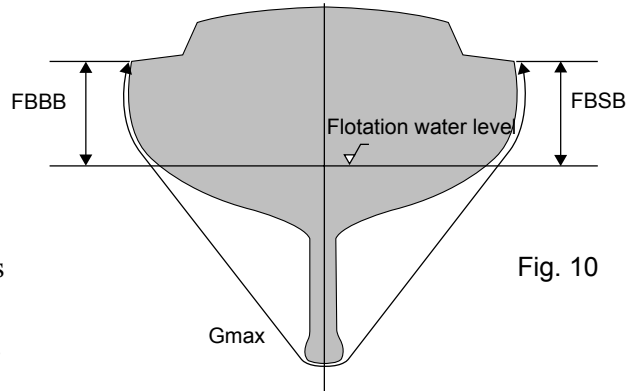

Fig. 10

Wing keels and centreboards are permitted. Centreboards shall be fully down and locked for measurement and whilst racing.  $SG_{max}$  shall be the distance from the  $G_{max}$  station to the stem, measured at the centre plane of the hull.

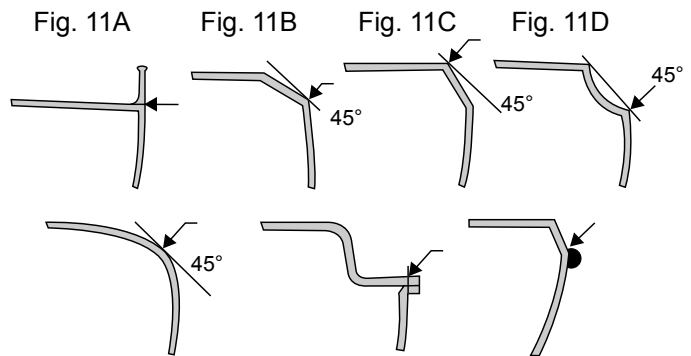

Fig. 11E

Fig. 11F

Fig. 11G

FBSB and FBBB shall be the starboard and port freeboards, measured vertically from the sheer line to the flotation measurement waterline at the  $G_{max}$  station ( $SG_{max}$ ) (see fig. 10 and 11A-G).

The point on the sheer line as defined for measuring  $G_{max}$ , FBSB and FBBB shall be placed on the fair curve or straight line, which forms the sheer line of the hull from stem to transom.

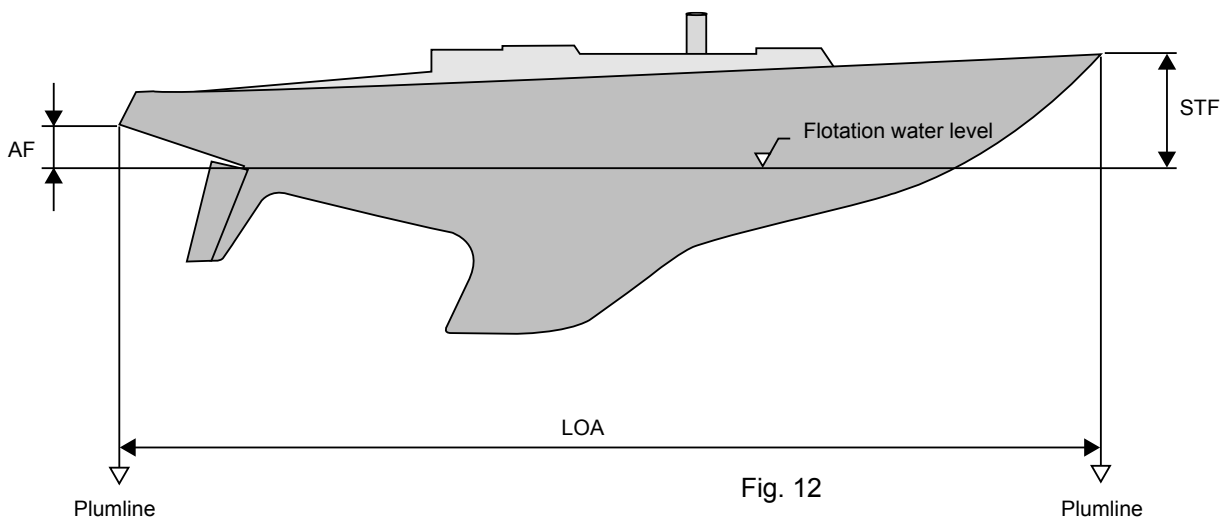

Fig. 12

## 4.1.4 Freeboards Fore and Aft

STF shall be the forward freeboard, measured vertically from the stem head fitting to the flotation measurement waterline at the vertical centre plane of the hull (see fig. 12).

# Danish Handicap

AF shall be the aft freeboard, measured vertically from the point at the extreme aft end of LOA to the flotation measurement waterline at the vertical centre plane of the hull (see fig. 12).

STF and AF are measured to verify the measurement trim of the boat.

## 4.2 Sail and Rig Measurement

Sails shall be measured in accordance with the ISAF Equipment Rules of Sailing (ERS), except where varied herein. Where a term defined or a measurement given in the ERS is used in these rules it is printed in bold *Italic* type.

### 4.2.1 Total Sail Area, S

(S is used for calculation of SV)

$$S = SSA + FA2 + [(SA - (SSA + FA2)) / 2]$$

If  $[(SA - (SSA + FA2)) / 2] < 0$ ,

then  $[(SA - (SSA + FA2)) / 2]$  shall be set to 0 (zero).

The area of each sail is derived from the formulae below.

### 4.2.2 Mainsail Area, SSA

$$SSA = 0,125 * P * (2 * E + 3 * MGM + 2 * MGU + HB)$$

P shall be the measured length of the hoist of the mainsail. P is the distance along the aft side of mast from the highest level to which the **Head Point** (ERS G.4.2) of the sail may be set to the lowest position of the track. The highest point shall be taken as the top of the highest sheave used for the main halyard, or to the lower edge of the **Upper Limit Mark** (ERS F.5.5 and F.6.2)

The lowest position of the track shall normally be the fair extension of the top of the boom or any external track or groove, which shall be at level with the upper edge of the **Lower Limit Mark** (ERS F.5.4 and F.6.1) (see fig. 13).

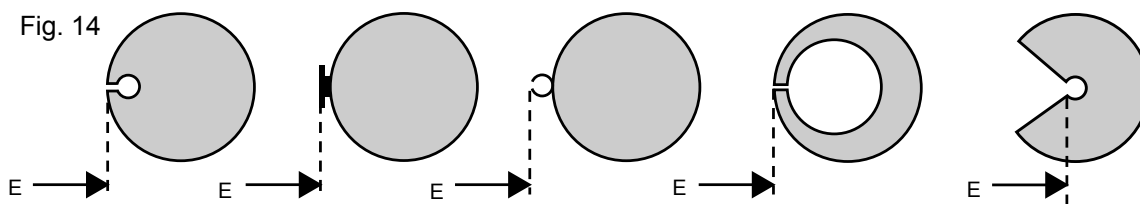
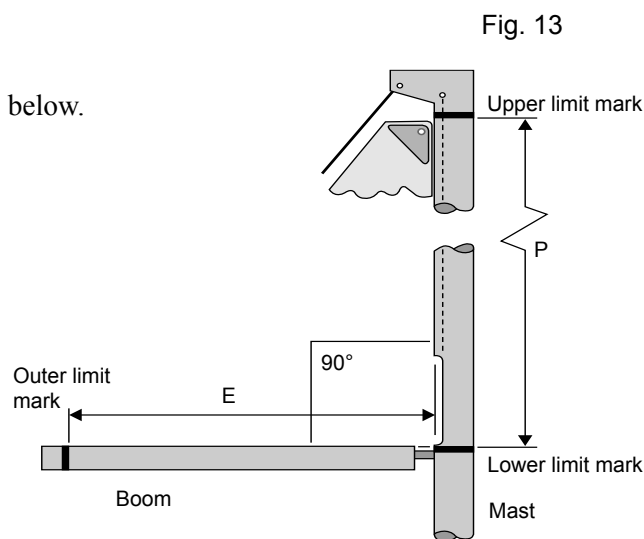

E (ERS F.12.1) shall be the mainsail boom length. E is measured at right angles to the mast along the boom upper side from the aft side of the mast - including any external track or groove (see fig. 14), or its fair extension parallel to the axis of the mast - to the aftermost position to which the **Clew Point** (ERS G.4.1) of the mainsail is permitted to extend, or to the innermost edge of the **Outer Limit Mark** (ERS F.11.1) on the boom (see fig. 13).

# Danish Handicap

MGM shall be the **Half Width** (ERS G.7.5) of the mainsail.

MGU shall be the **Three-quarter Width** (ERS G.7.6) of the mainsail.

HB shall be the **Top Width** (ERS G.7.8) of the mainsail.

A rotating mast (wing mast) is permitted when the mainsail area is corrected. When a rotating wing mast is used the maximum dimension of the mast cross section shall be added to E, MGM, MGU and HB. The maximum dimension of the mast cross section shall be noted on the rating certificate together with the statement that E, MGM, MGU and HB have been corrected accordingly.

## 4.2.3 Head Sail Area, FA1, FA2, FA3

$$FA1 = 0,5 * T_{max} * (LP + FSP)$$

$$FA2 = 0,25 * T_{max} * (J + LP + (2 * FSP))$$

$$FA3 = 0,5 * T_{max} * (J + FSP)$$

RRS 50.4 shall be used to distinguish between headsail and spinnakers.

Tmax shall be the maximum **Luff Length** (ERS G.7.3), measured on any headsail. Tmax shall not be taken as less than  $0.75 * ISP$  when calculating the time allowances.

If the **Top Width** (ERS G.7.8) of the headsail is greater than  $0.02 * J$ , then the **Head Point** (ERS G.4.2) for the Tmax measurement shall be the intersection of the **Luff** (ERS G.2.3) and **Leech** (ERS G.2.2), each extended if necessary (see fig. 15A and 15B).

LP shall be the maximum **Luff Perpendicular** (ERS G.7.11) measured on any headsail.

LP shall not be greater than  $0.65 * T_{max}$

If  $LP < J$ , then J shall be set to LP when calculating FA2 and FA3. LP shall not be taken as less than  $0.75 * J$  when calculating the time allowances.

RRS 50.4 shall apply to all headsails. Except, where class rules (RRS 86.1) of international or national One-Design classes permit wider sail widths, all boats of that specific class shall have the maximum roach of the headsail, JR (e.g. 0.12 m), added to LP before calculating the time allowance.

JR, Jib Roach, where permitted (see 3.1.2 c), shall be

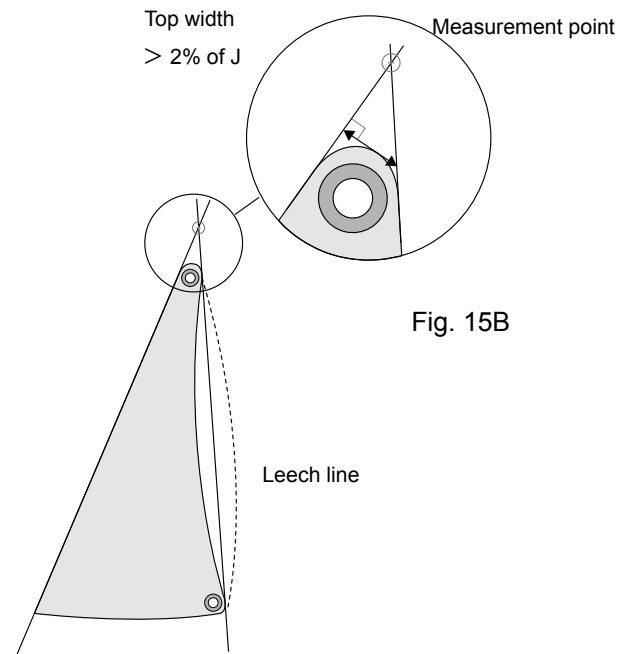
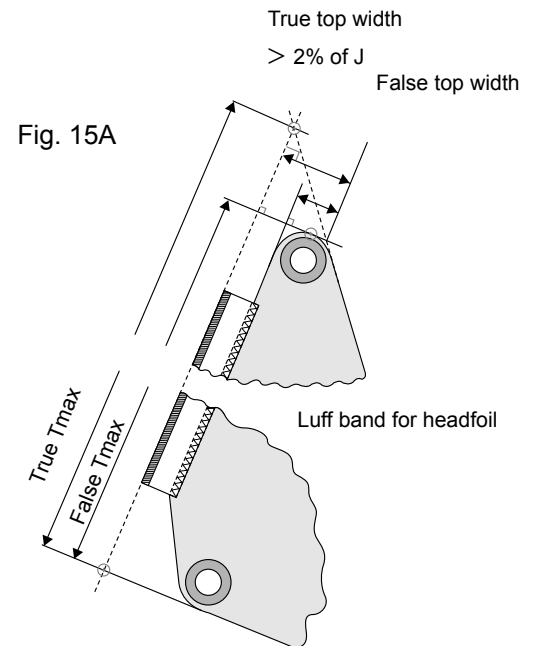

# Danish Handicap

measured as the maximum excess of the **Quarter Width** (ERS G.7.4), **Half Width** (ERS G.7.5) or **Three-quarter Width** (ERS G.7.6) of the headsail as defined in RRS 50.4 (see fig. 16). The maximum roach dimensions of a class shall be noted on the rating certificate.

J (ERS F.3.1) shall be the base of the fore triangle, measured horizontally from the foreside of the mast at its lowest point above the deck or coach roof to the intersection point between the deck or bowsprit and the centre line of the foremost stay on which a headsail is set, extended if necessary (see fig. 17). The forestay may either be permanently affixed to the boat or built into the luff of the headsail, i.e. it may be removed with the headsail.

If a headsail can be set on the boat on an inner forestay aft of the foremost forestay – whereto J is measured – the intersection point between the deck and the centre line of the inner forestay, extended if necessary, shall not be less than  $0.60 * J$  forward of the foreside of the mast, measured in the same manner as J.

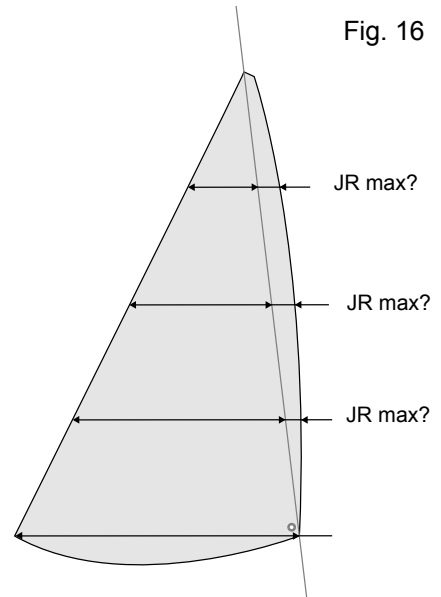

Fig. 16

Fig. 17

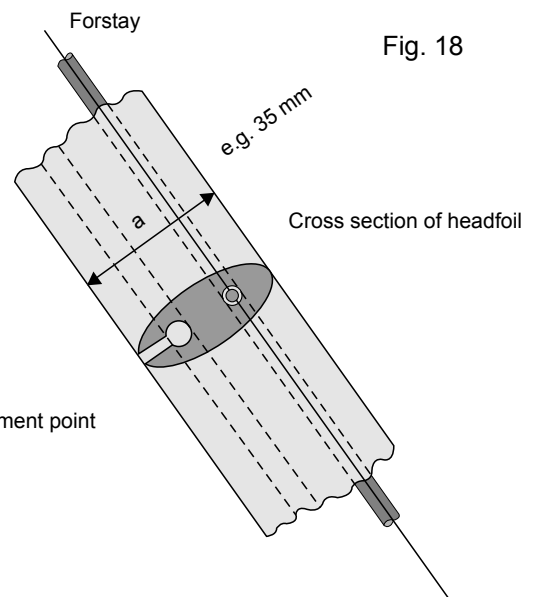
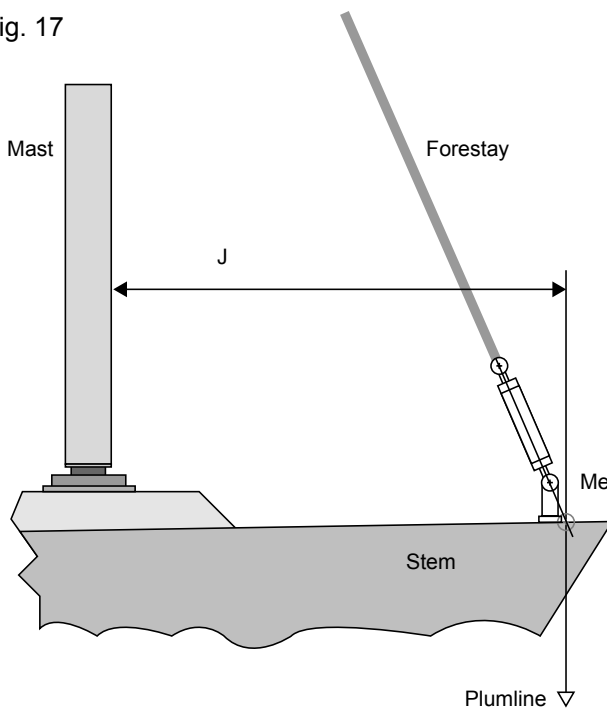

Fig. 18

FSP shall be twice the maximum dimension of a forestay luff groove (headfoil) or furling device, measured at right angles to its longitudinal axis (see fig. 18).

# Danish Handicap

## 4.2.4 Area of Symmetric and Asymmetric Spinnaker, SA

$$SA = 0,06 * [2 * SLB + ((SFB + SMWB) / 2)]^2 + [SLB * (SPLB - J)]$$

RRS 50.4 shall apply as to distinguish between headsail and spinnaker. The symmetric spinnaker shall be symmetrical about its centreline, **Foot Median** (ERS G.7.10).

Symmetric spinnakers shall be measured folded along the **Foot Median** (ERS G.7.10) with the **Leeches** (ERS G.2.2) together.

Asymmetric spinnakers shall be measured unfolded.

If the spinnaker luff length is greater than or equals 1.05 times the leech length the spinnaker shall be measured as asymmetric – thus,  $SLU \geq 1.05 * SLE$  (see fig. 19).

SLB shall be the greater of SL or  $(0.6 * SLU + 0.4 * SLE)$  or  $(0.96 * ISP)$ .

SL shall be the greatest **Leech Length** (ERS G.7.2) measured on any symmetrical spinnaker.

SLU shall be the greatest **Luff Length** (ERS G.7.3) measured on any asymmetric spinnaker (see fig. 19).

SLE shall be the greatest **Leech Length** (ERS G.7.2) measured on any asymmetric spinnaker (see fig. 19).

SFB shall be the greater of SF or SFA.

SMWB shall be the greater of SMW or SMWA.

SPLB shall be the greater of SPL or TPS. SPL and TPS shall not be taken as less than J.

ISP shall be the height of the spinnaker halyard. It shall be measured from the underside of the spinnaker halyard, when drawn horizontally from the mast, to the level of the sheer line abreast the mast (see fig. 20 and 11A-G in paragraph 4.1.3). If the boat has no spinnaker halyard, ISP shall be taken as  $0.75 * P$  when calculating the time allowances.

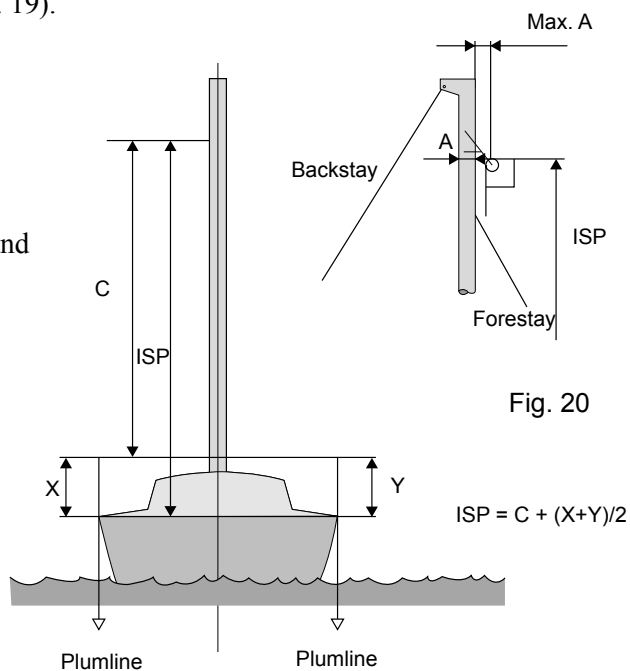
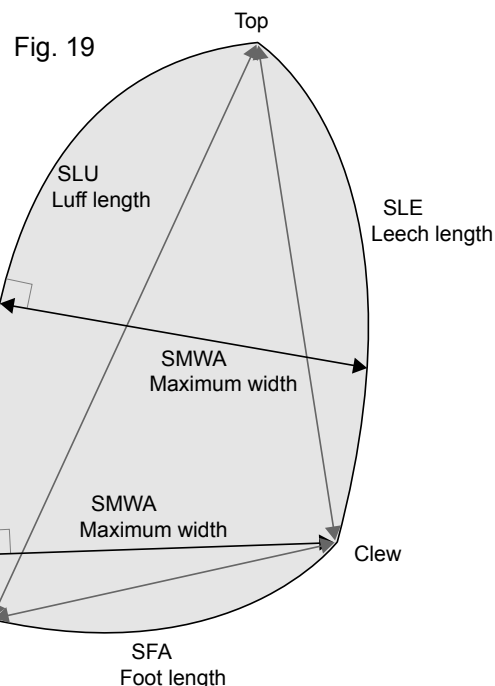

# Danish Handicap

The bearing point of the spinnaker halyard and the block shall not be more forward of the foreside of the mast than the maximum fore and aft width of the mast.

SF shall be the maximum **Foot Length** (ERS G.7.1) measured on any symmetric spinnaker. With the symmetric spinnaker folded along the **Foot Median** (ERS G.7.10) and the **Leeches** together, the half of SF is measured as the shortest distance between the **Clew Point** (ERS G.4.1) and the **Foot Median** (ERS G.7.10) ( $\frac{1}{2}$ SF).

Remember to multiply this half measurement with 2 to obtain SF.

SFA shall be the greatest **Foot Length** (ERS G.7.1) measured on any asymmetric spinnaker. SFA is measured as the distance between the **Clew Point** (ERS G.4.1) and the **Tack Point** (ERS G.4.3) of the asymmetric spinnaker (see fig. 19).

SMW shall be maximum width measured on any symmetric spinnaker. SMW is measured either at the **Foot** (ERS G.2.1) or across the body of the sail between points on the **Leeches** (ERS G.2.2) equidistant from the **Head Point** (ERS G.4.2).

With the symmetric spinnaker folded along the **Foot Median** (ERS G.7.10) and the **Leeches** (ERS G.2.2) together, the half of SMW is measured as the shortest distance between the points on the **Leeches** (ERS G.2.2) and the **Foot Median** (ERS G.7.10) ( $\frac{1}{2}$ SMW).

Remember to multiply this half measurement with 2 to obtain SMW.

SMWA shall be maximum width, measured on any asymmetric spinnaker. SMWA shall be the shortest distance between any point on the **Leech** (ERS G.2.2) and the **Luff** (ERS G.2.3), measured across the widest part of the **Sail** (ERS G.2.1) (see fig. 19).

SPL shall be the length of the spinnaker pole when forced outboard in its fitting on the mast and set in a horizontal position athwartships, measured from the centre line of the mast to the extreme outboard end of the pole and any fitting used when a spinnaker is set (see fig. 21). SPL shall not be measured/registered when spinnakers are not included in the sail inventory.

TPS shall be the distance from the fore side of the mast at its lowest point above the deck or coach roof to the point of attachment at deck level of the foremost tacking point of an asymmetric spinnaker

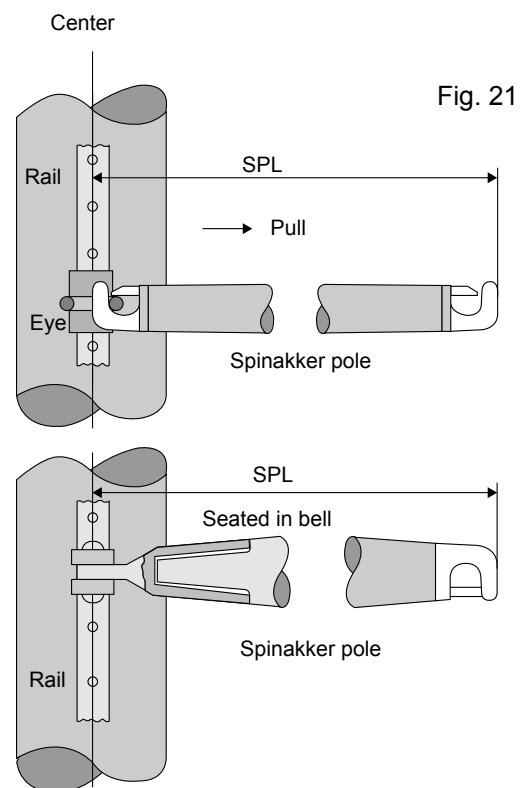

# Danish Handicap

or to the extreme forward end of any bowsprit or its **Outer Limit Point** (ERS F.16.1 and F.17.2) when extended in its maximum position.

## 4.2.5 Sail Certification Mark

New and old sails measured for the first time or sails substantially altered shall be measured by an **Official Measurer** (ERS C.4.3) who shall affix the **DSA Certification Mark** (ERS C.5.4) (official stamp or sail button) onto the **Tack** (ERS G.3.3) of the sail - onto the **Head** (ERS G.3.2) of spinnakers - and near this his signature and date shall be indelibly written with weatherproof ink. Sails with an official **Certification Mark** (ERS C.5.4) affixed, from another ISAF National Authority complies with the requirements of this rule.

Sails measured earlier than 1990 may carry the official stamp, "Scandicap" or "DS Autoriseret Måler", and near this the signature of the measurer and date shall be indelibly written with weatherproof ink.

All sails carried on board whilst racing shall carry the **Certification Mark** (ERS C.5.4).

## 4.2.6 Rig Type, Sloop/Bermuda

DH describes only sail measurement and sail area calculation for boats with Sloop/Bermuda rig. Other rig types may be rated under DH. Please contact DSA Chief Measurer for further details.

## 4.2.7 Mast Factor, MF

MF is as follows:

- Mast of aluminium, steel and wood implies no correction of the time allowance
- Mast of carbon fibre reinforced plastic implies a correction of the time allowance due to the lower weight of the mast

No correction of time allowance is applied for main boom, spinnaker poles and jockey poles of carbon fibre reinforced plastic.

## 4.3 Propeller Type, PF

1. None

Propeller of exposed shaft and strut drive (see fig. 22A, 22B, 22C):

2. Out of aperture folding propeller with 2-3 blades
3. Out of aperture feathering propeller with 2-3 blades
4. Out of aperture solid propeller with 2 blades
5. Out of aperture solid propeller with 3-4 blades

Propeller in aperture of deadwood or rudder (see fig. 22D):

6. In aperture folding propeller with 2-3 blades

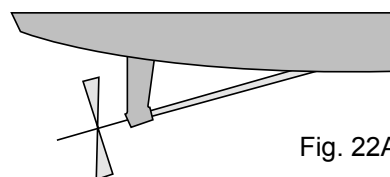

Fig. 22A

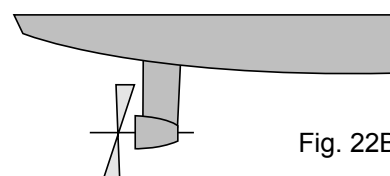

Fig. 22B

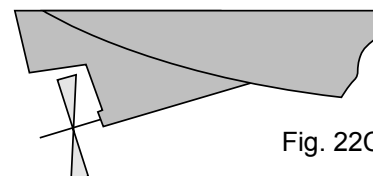

Fig. 22C

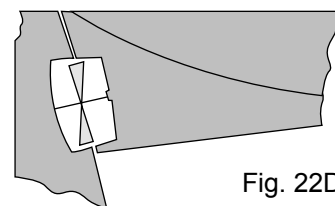

Fig. 22D

# Danish Handicap

---

7. In aperture feathering propeller with 2-3 blades
8. In aperture solid propeller with 2 blades
9. In aperture solid propeller with 3-4 blades

To qualify for a propeller installation, different from “None” when calculating the time allowance, the boat shall be capable of speed under power with the propeller in smooth water and without assistance of wind of not less than:

$$\text{Minimum speed} = 2 * (L)^{0.5} \text{ [knots]}$$

## Sailing time [s]

Testing distance [m]	50	75	100	125	150	175	200	225
Min. speed [knots]								
3,00	32,4	48,6	64,8	81,0	97,2	113,4	129,6	145,8
3,25	29,9	44,9	59,8	74,8	89,7	104,7	119,6	134,6
3,50	27,8	41,7	55,5	69,4	83,3	97,2	111,0	125,0
3,75	25,9	38,9	51,8	64,8	77,8	90,7	103,7	116,6
4,00	24,3	36,5	48,6	60,7	72,9	85,0	97,2	109,3
4,25	22,9	34,3	45,7	57,2	68,6	80,0	91,5	103,0
4,50	21,6	32,4	43,2	54,0	64,8	75,6	86,4	97,2
4,75	20,5	30,7	40,9	51,2	61,4	71,6	81,9	92,1
5,00	19,4	29,2	38,9	48,6	58,3	68,0	77,8	87,5
5,25	18,5	27,8	37,0	46,3	55,5	64,8	74,0	83,3
5,50	17,7	26,5	35,3	44,2	53,0	61,8	70,7	79,5
5,75	16,9	25,4	33,8	42,3	50,7	59,2	67,6	76,1
6,00	16,2	24,3	32,4	40,5	48,6	56,7	64,8	72,9

## 4.4 Hiking Straps, HF

The use of hiking straps is permitted, provided these are measured and accounted for in the time allowance of the rating certificate.

When hiking straps are not prohibited according to class rules of international or national One-Design classes (e.g. 606, H-Boat, Soling, X79 and Yngling) all boats of those classes shall have hiking straps accounted for in the calculation of the time allowance. (See paragraph 3.1 paragraph 2b and RRS 49.1 RRS 86.1 (c)). All class boats of these classes may use hiking straps to project outboard the weight of the crew.

All non-class boats can be rated separately with hiking straps.

The fact that some boats fitted with hiking straps sail faster, when reaching, is accounted for when calculating their time allowances.

# Danish Handicap

## 4.5 Keel

### 4.5.1 Keel Weight, K

K shall be the total weight of the outside ballast keel and the interior ballast.

Any material used in the outside ballast keel or interior ballast shall have a density not greater than that of lead (11.35 t/m<sup>3</sup>).

Any material used as a “deadwood piece” having a density greater than 1.6 t/m<sup>3</sup> shall be calculated as keel weight.

Any item of equipment of abnormal size or weight for the size of boat, which is situated in the interior of the boat and below the flotation waterline, shall be calculated as keel weight (e.g. anchor, floor timber, batteries, tankage and engine weight).

If K is less than  $D/3$ , K is corrected to  $K_{corr}$ .  $K_{corr}$  shall not be taken less than  $D/3$ , when calculating the time allowance.

### 4.5.2 Keel Chord, KC

The Keel Chord is the fore and aft length of the keel, measured between measurement points on the leading and trailing edge of the keel.

The measurement points are placed 1/3 of the keel height up from the tip of the keel (see fig. 23A, 23B, 23C, 23D, 23E, 23F, 23G).

The points on the leading and trailing edges are found by measuring the length of each edge from the keel tip to the keel top at the bottom of the canoe body (hull) at the centre plane of the hull. Then mark the lower 1/3 point on each edge.

Keel Chords not measured are set to values matching the equivalent of a slender fin keel, when the time allowance is calculated.

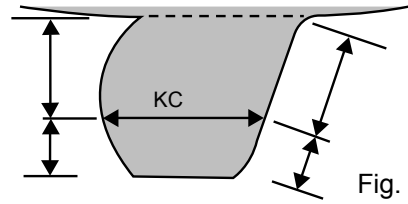

Fig. 23A

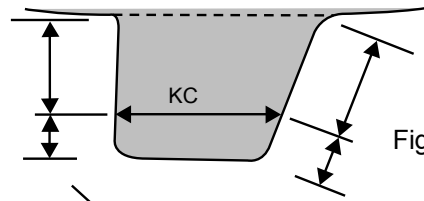

Fig. 23B

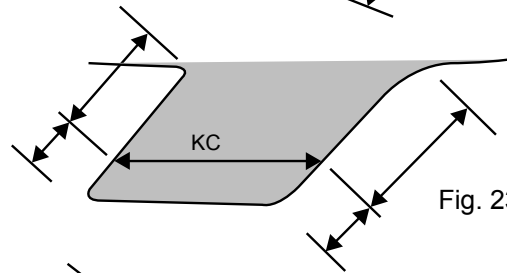

Fig. 23C

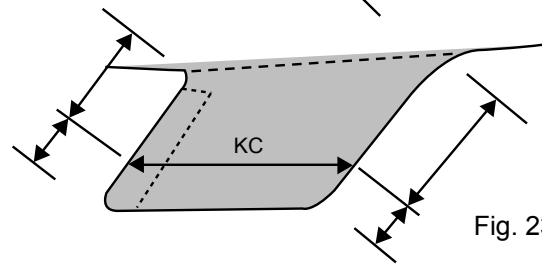

Fig. 23D

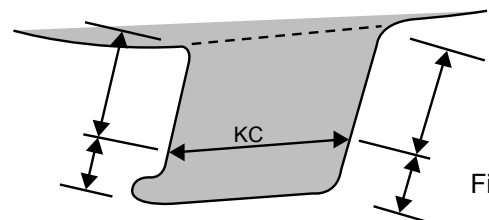

Fig. 23E

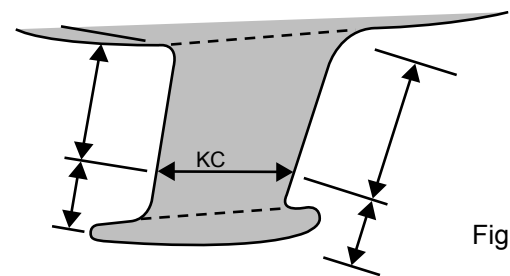

Fig. 23F

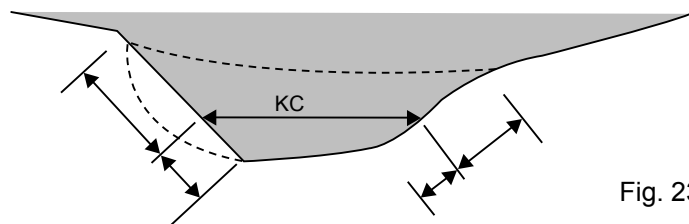

Fig. 23G

# Danish Handicap

## 4.5.3 Keel Factor, KF

The Keel Factor is used to categorise the vertical centre of gravity of the keel (VCG).

KF is as follows:

- Normal VCG, if seen from ahead the keel thickness is approximately equidistant at top and tip (see fig. 24A)
- Low VCG, if seen from ahead the keel thickness is gradually increasing from top to tip (see fig. 24B)
- Bulb, if the keel has a torpedo or bulb affixed at the tip (see fig. 24C)
- No data, if KF is not registered, the default value, KF = Bulb, is used to calculate the time allowance (see fig. 24C)

If the measurer's visual assessment of the Keel Factor (KF) gives a false image of the vertical centre of gravity (VCG), KF is to be determined by the TC. The owner is responsible for the measurer being given the correct details of the VCG of the keel. Any questions regarding determination of KF shall be referred to the DSA Chief Measurer.

## 4.6 Displacement, D

D shall be the total displacement weight of the boat in measurement trim, completed and equipped for racing. Measurement trim, see paragraph 4.7.

The displacement of boats shall be weighed with an accuracy of less than 2%. The displacement of hull standards is derived from actual weighing of boats. When at least 5 boats of one class have been weighed, DSA may establish the standard displacement from the formula:

$$D = D_m - [\text{SUM } (D_i - D_m)^2 / n]^{0,5}$$

- D = standard displacement used to calculate the time allowance
- D<sub>m</sub> = average displacement derived from the weighed boats
- D<sub>i</sub> = displacement of each of the weighed boats
- n = number of the weighed boats

When calculating the standard displacement of a class the standard hull dimensions (see [www.websejler.dk](http://www.websejler.dk)) are calculated by DSA according to identical principles.

1. If the displacement weight of a boat is 10% or more above the standard displacement, the owner may request that the boat does not use the standard hull dimensions of the class.
2. If the displacement weight of a boat is 2% or more below the standard displacement, the boat shall not use the standard hull dimensions of the class.

If a boat is not using the standard hull dimensions of the class, its hull shall be measured and weighed individually.

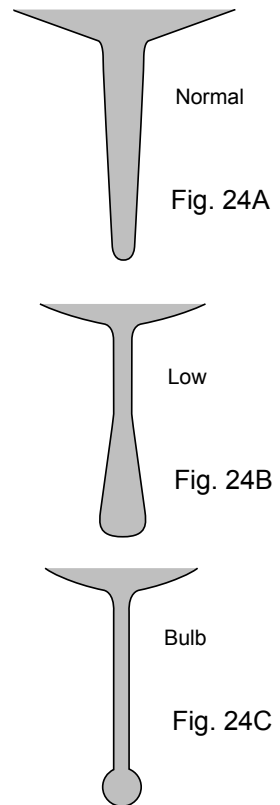

# Danish Handicap

---

Movable water ballast is permitted. The weight [kg] of the water ballast contained in the interior ballast tank at the one side of the boat shall be registered and noted on the rating certificate. The fact, that the water ballast would be bailed out on down wind courses, explains why the weight of the water ballast is not included in the displacement of the boat. Therefore the boat shall be measured and its displacement weighed with empty ballast tanks. On the other hand, the water ballast would be included when calculating the total righting moment of the boat.

The righting moment caused by the water ballast is calculated as a supplement to the righting moment of the crew. This is managed by calculating a fictive increase of the moment arm for the established crew weight (the fictive increase of the moment arm is noted as UDHBmax og UDHmax, see paragraph 4.1.2).

## 4.7 Measurement Trim

In due time before the measurement the measurer is recommended to hand out a copy of the following check list to the boat owner to assist the owner prepare the boat for measurement.

### Check list

Measurement condition for measurement afloat and weighing:

1. Except for not more than 10 litres of fuel in the fuel tank, all tankage and voids shall be empty
2. No outboard motor shall be on board
3. No loose equipment shall be on board (e.g. mattresses, spare sails, life raft, dinghy, clothing, food, stores, cooking equipment, bedding, dining table, etc.)
4. One suit of sails shall be on board (e.g. 1 mainsail, 1 jib, 1 genoa (if carried) and 1 spinnaker (symmetric or asymmetric))
5. All other necessary equipment according to RRS 51 shall be kept on board (e.g. hatches, ladders, floor boards, spars, anchor with warp and chain, fenders, sheets and guys, mooring lines, halyards etc.)
6. All portable equipment under item 4 and 5 shall be placed on the cabin sole abaft the mast and not more than 1.50 m abaft the mast
7. The mast shall be raked aft to its normal limit of adjustment and not raked forward of vertical
8. All standing rigging shall be tight
9. All running rigging shall be slack
10. The boom shall be at its lowest point, perpendicular to the mast (see paragraph 4.2.2), at the centre plane of the hull and secured against movement
11. The spinnaker pole(s) shall be in its normal stowage
12. The centreboard shall be locked fully down (also whilst racing)
13. No person shall be on board during the flotation measurement
14. Any heavy equipment (e.g. interior ballast, batteries, etc.) shall be secured to prevent movement (glassed in or bolted) and its weight and distance from the stem noted on the rating certificate.

## 5.0 Measurement Procedure

### 5.1 Measurement Procedures

Measurement procedures are as laid down in the DH rule and decided by TC.

### 5.2 Measures

DSA clubs elect their own measurers and are responsible for their work. Measurers are subject to the restrictions laid down in paragraph 5.2.2. Before club measurers carry out any measurement to be used under DH, they shall participate in a DSA measurer's course and obtain approval from DSA.

#### 5.2.1 Measurement Equipment

The measurer should have the following equipment:

- Min. 15 m long steel tape measure
- Min. 2 m long tape measure and folding rule
- Min. 2 plumb-lines with cone shaped plummets
- One plummet to hang from the middle of the tape measure underneath the boat during the Gmax measurement
- Masking tape (can be left out)
- Floating overhang ruler
- Punch, ø 18 mm, hammer, wooden blocks and thermos with hot water for attaching the DSA sail buttons on all racing sails
- A beam or rail for beam measurement etc. (spinnaker pole can be used instead)

#### 5.2.2 Measurer's task and restrictions

##### Measurer's task:

- The measurer shall measure the boat as accurately as possible and register the measurements and other details on the measurement form, enabling the DSA to issue the rating certificate for the boat.
- To DSA (and all measured boats) the measurer shall be the guarantor of measurement uniformity and justice.
- In order not to be accused of acting as an interested party the measurer shall not be a consultant to the boat owner.

##### No measurer shall measure:

- Boats designed or built, wholly or partly, by himself or in the reconstruction of which he has taken part
- Boats built by a boatyard in which he has a vested interest or is employed
- Boats owned, wholly or partly, by himself or in which he is an interested party, e.g. as crew member

In these cases the committee of the club shall assign an alternative measurer and, if necessary, a measurer from another club according to agreement with the other club's committee.

## **5.3 Rating Certificate and Standardising of Measurement Data**

### **5.3.1 DH Rating/Measurement Certificate**

The Rating/Measurement Certificate is an official document. A copy of the current Rating/Measurement Certificate or the original shall always be on board the boat. On request the Rating/Measurement Certificate shall be produced.

The Rating/Measurement Certificate, which is valid until the date stated on the certificate, shall be issued in the name of the owner. If required, the DSA can withdraw the Certificate before this date and may re-issue it. Except for an IMS rating certificate, no boat shall have more than one valid DH Rating/Measurement Certificate at any one time.

When measurement is completed the measurer reports the result to DSA either on a measurement form or via [www.websejler.dk](http://www.websejler.dk).

DSA collects a fee for all Rating/Measurement Certificates issued. The Rating/Measurement Certificate is sent directly to the owner's address. A copy of the Rating/Measurement Certificate is kept by DSA.

On receipt of a new Rating/Measurement Certificate the owner, if needed assisted by a measurer, shall check that the boat complies with the Certificate. It is the responsibility of the owner to report any non-compliance to DSA. It is the owner's responsibility that the boat complies with all information and data on the Rating/Measurement Certificate.

### **5.3.2 Issue of DH Rating Certificate**

The conditions for issue of DH Rating Certificate are:

1. The boat shall be of normal design, i.e. comply with the regulations of paragraph 3.0 and not contravene the DH rule in general
2. The boat owner shall be a member of a DSA recognised club
3. The boat shall be measured only at the owner's club
4. The only exception from item 3 (see also paragraph 5.2.2) is the case where a club has no measurer of its own and assigns a measurer from another club. The club shall inform its members of this agreement and to whom it has assigned the measurement job
5. All sails of the boat used for racing shall be measured and have the DSA sail button affixed (see DSA prescription to RRS 78.). When sails are measured by a DSA licensed sail loft a DSA sail button must be affixed at the loft
6. Only the current Rating/Measurement Certificates shall be used for racing. This can be verified via the DSA Boat Database on [www.websejler.dk](http://www.websejler.dk)

### **5.3.3 One-Design Classes with Closed Class Rules**

DH Rating Certificates are not issued for boats of international, Scandinavian and national one-design classes with closed class rules. Instead Measurement Certificates are issued with matching standard time allowances.

# Danish Handicap

---

Since the standard time allowances had been derived by TC from the class rules, the standard time allowances shall only apply if the boat holds a current Measurement Certificate and complies with its class rules. The time allowances and standard data can be seen on [www.websejler.dk](http://www.websejler.dk).

Only when a one-design class boat is altered so that it does not comply with the One-Design Class Closed Class Rules a DH Rating Certificate is issued. In that case the actual measurement data will appear on the rating certificate. If the hull of the boat is not altered the time allowances are derived from the class standard hull with matching displacement, keel weight and the actual sail and rig data.

### **5.3.4 One-Design Classes with Open Class Rules**

DH Rating Certificates are issued for boats of national one-design classes with open class rules. The matching standard time allowances are shown on the DH Rating Certificate of each boat. Since the standard time allowances are derived from the class rules, the standard time allowances shall only apply if the boat complies with its class rules. The DH Rating Certificate is issued on the basis of the class standard hull with matching displacement, keel weight and the maximum sail and rig data of the class. The time allowances and standard data can be seen on [www.websejler.dk](http://www.websejler.dk).

The measurer shall measure the sails, rig and the freeboards FBSB, FBBB, STF and AF according to the class standard hull. Measurement data and any other information are reported to DSA for issue of the rating certificate. See paragraph 5.3.1.

Only when a boat is not complying with the One-Design Class Open Class Rules a DH Rating Certificate for "Other Boats" is issued, see paragraph 5.3.6. In that case, the altered class status is indicated on the rating certificate. If the hull of the boat is not altered the time allowances are derived from the class standard hull with matching displacement, keel weight and the actual sail and rig data.

### **5.3.5 Standard Hulls**

The purpose of, a "DSA Standard Hull" for series produced boat classes, is to neutralise influence of building tolerances at the hull manufacture and measurement variations of different measurers hull measurements and variations of flotation measurement trim of different boats of the same class.

Using a "DSA Standard Hull" should exclude any "exploitation" of the rule during hull measurement. As mentioned in paragraph 4.6, there is room for some variation of the displacement, when series produced boats belong to the same class all are using a "DSA Standard Hull". It would therefore also be possible to fit, for example a rubbing strake, without requiring an individual hull measurement. However, fitting for example a special keel or rudder would require an individual hull measurement.

# Danish Handicap

---

DH Rating Certificates are issued for boats of classes having a class standard hull.

When at least 5 boats of a series produced class have been measured and weighed, the TC may establish a class standard hull (incl. flotation measurements) with matching displacement (see paragraph 4.6) and keel weight. Until then, all boats are measured individually including complete hull measurement and weighing.

The time allowances of a series produced class are derived from the class standard hull and the actual sail and rig data of the boat. The time allowances and standard data can be seen on [www.websejler.dk](http://www.websejler.dk).

The measurer shall measure the sails, rig and freeboards FBSB, FBBB, STF and AF according to the class standard hull. Measurement data and any other information are reported to DSA for issue of the rating certificate. See paragraph 5.3.1.

If a boat is not complying with its class standard hull measurements the boat shall be measured completely and weighed. See paragraph 5.3.6, Other Boats.

The final assessment and approval of class standard hull dimensions, including matching displacement and keel weight, shall be made by the TC.

## **5.3.6 Other Boats**

DH Rating Certificates are issued for Other Boats only when completely measured and weighed.

The measurer shall measure sails, rig and hull, including weight, of the boat.

Measurement data and any other information are to be reported to DSA for issue of the rating certificate, see paragraph 5.3.1.

The following shall apply:

Relevant data from current IMS-certificate may be used to calculate the time allowance, i.e. LOA, Bmax, SBmax, D (DSPM), P, E, MGM, MGU, ISP, SL, SMW, SLU, SLE, LP (LPG), FSP, J, SPL and TPS.

Thus, to be measured are Gmax, SGmax, FBSB, FBBB, UDFSB, UDFBB, UDHBmax, UDHmax, OF, OA, STF, AF, K, KC, KF, Tmax, SF, SFA and SMWA.

The time allowances and measurement data can be seen on [www.websejler.dk](http://www.websejler.dk).

## **5.3.7 Alterations after Measurement**

Alterations affecting the measurement data necessitate issuance of new rating certificate.

If new sails are purchased they shall be measured and have the DSA sail button affixed by a DSA approved measurer or authorised sail loft. Any alterations of the rating certificate are made by DSA. New data are forwarded to DSA. A fee is collected for new rating certificates issued.

Altering the boat's measurement trim by increasing, moving or reducing interior ballast or equipment is prohibited.

# Danish Handicap

## 5.3.8 Measurement Control

At any time the measurements of a boat can be checked and its rating certificate altered accordingly.

## 5.3.9 Rating Certificate on Change of Ownership or Club

To be valid change of ownership or club shall be registered on the rating certificate of the boat. The change must be notified to DSA, who shall register the new owner and/or club on the rating certificate of the boat. A fee is collected for the rating certificate issued for the new owner.

## 6.0 Race Management

### 6.1 How to Choose Time Allowance

The Time Allowances shown on the DH Rating Certificate are given in sec/nautical mile [s/nm] to the first place of decimal and expresses the boat speed at the wind speed of 6 m/s (12 knots) on the following racecourses:

TA	General TA, with approx. 38% beat, 10% close reach, 10% beam reach, 28% broad reach and 14% run
TANS	Identical to TA, but without spinnaker
TAUD	Windward-Leeward, with 50% beat and 50% run
TANSUD	Identical to TAUD, but without spinnaker

The time allowances for the different types of racecourses are characterised by the distribution of beat, close reach, beam reach, broad reach and run of the course length expressed in percentages. Each leg of the racecourse is assumed to be a straight line between the marks.

The percentage distribution between beat and run on the different racecourses is calculated as VMG, which is the optimum course and speed stated as the speed (time allowance) sailed on a straight course to the next mark. Thus, the extra distance sailed on the beat is included in the time allowances.

Before the start of the race the Race Committee shall choose the time allowance for the actual racecourse with due consideration to the distribution of the different courses. When boats are racing on the same racecourse, i.e. identical distance and courses, the same type of time allowance shall be chosen for all boats.

For instance, on the same racecourse it would not be correct to let some boats use TA and others TAUD. However, TA and TANS could be chosen for boats on the same course. This also applies for the corresponding time allowances – with and without spinnaker - TAUD and TANSUD. The Race Committee's choice of time allowance shall not be the subject of request for redress according to RRS 62.1 (a).

# Danish Handicap

---

## 6.2 Dividing Fleet into Classes

As the racecourse wind speed is not taken into consideration when choosing the time allowance it is necessary to divide the fleet into classes to give fair racing.

When dividing boats into classes their relative speed profiles should be taken into consideration, for example by dividing them according to their performance characteristics in heavy and light weather, supplemented by size or speed according to their time allowances. Therefore, it should be avoided including boats with spinnaker and boats without spinnaker in the same class. Of course, other methods based on experience of the boats and their crews would be appropriate. The real issue here is to divide boats into classes in order to achieve the most fair and enjoyable racing.

One-design classes with measurement certificates only use their standard time allowances when not class racing.

Once the classes of a race have been settled, do not spoil it all by scoring the total race by calculating an “over-all-result”. This would only once again put all boats back together into one big class!

“Over-all-results” only makes sense if the wind speed on the racecourse had been 6 m/s. At all other wind speeds the chances of winning for the different types of boats would be uneven.

## 6.3 Scoring

DH-races are scored according to the method of “time on distance”:

$$CT = ET + [(TAS - TAA) * CL]$$

- CT is the corrected time, rounded to the capital number of seconds
- ET is the elapsed time produced by timing each participating boat in the race from start to finish in capital number of seconds
- TAS is the time allowance of the scratch boat on the chosen racecourse - the slowest boat of the race - the boat with the greatest time allowance. This might be an imaginary boat, e.g.  
TAS = 1000 s/nm
- TAA is the chosen time allowance for any boat on the actual racecourse
- CL is the length of the racecourse in nautical miles [nm]

The boat with the smallest CT is the winner.

## 6.4 Pursuit Race

Pursuit race imply that the smallest and slowest boat is starting first and the biggest and fastest boat is starting last.

The starting time of each boat is calculated from their time allowances, so all boats – that is, if all were sailing equally “well” – should finish simultaneously!

# Danish Handicap

---

The advantages of pursuit race appear especially at the finishing part of the race, which can become very exciting and intense as the boats are scored in the order they cross the finishing line. It would be almost like “sailing in one-design class boats”. Furthermore, this way of starting could contribute towards removing the nerve-racking situations frequently occurring at normal starts, where boats are close to one another.

Calculation of respite:

$RESPITE = (TAS - TAA) * CL$  (the result shall be rounded to the cardinal number of seconds)

- TAS is the time allowance of the smallest and slowest boat (greatest time allowance) [s/nm]
- TAA (e.g. TA) is the time allowance of the actual boat [s/nm]
- CL is the length of the racecourse in nautical miles [nm]

Example: (30 nautical miles):

<b>Calculation</b>	<b>Respite</b>	<b>Starting time (clock time)</b>
$(1000 - 1000) * 30 = 0 \text{ sec.}$	0 hour 00 min. 00 sec.	At 10:00 (1. starting boat)
$(1000 - 800) * 30 = 6000 \text{ sec.}$	1 hour 40 min. 00 sec.	At 11:40 (2. starting boat)
$(1000 - 500) * 30 = 15000 \text{ sec.}$	4 hours 10 min. 00 sec.	At 14:10 (3. starting boat)

Remember to round the respite to cardinal number of seconds.

To convert the respite from seconds to hours, minutes and seconds divide the seconds by 3600 sec – and the result will be hours in decimal figure.

Example: (3856 sec.)

$3856 \text{ sec.} / 3600 \text{ sec.} = 1,071111111 \text{ hours} = 1 \text{ hour} + \text{remainder } 0,071111111 \text{ hours.}$

$0,071111111 * 60 \text{ min.} = 4,266666667 \text{ min.} = 4 \text{ min.} + \text{remainder } 0,266666667 \text{ min.}$

$0,266666667 * 60 \text{ sec.} = 16 \text{ sec.} + \text{remainder } 0,00 \text{ sec.}$

Thus, 3856 sec. = 1 hour 4 min. 16 sec.

This conversion is easily done on some pocket calculators.

## DANISH HANDICAP

The National Rating Rule of the Danish Sailing Association, Version 2004

© Dansk Sejlunion

Illustration and lay-out: Tine Finsen Grafik

Front cover illustration: William Vestervig

This book may be copied only with information of source

# Danish Handicap

---

## Amendments to DH version 2004

### March 2006

Amended item 2.a. in paragraph 3.1

When boats of national or international one-design classes are racing under the DH rule with their class-imposed time allowances, the class rules shall apply only to that extent to which they influence the DH measurement data used to calculate their one-design class rating.

**and**

Amended paragraph 3.1.6:

6. Boats rated with spinnaker may instead of the spinnaker set two (2) headsails simultaneously on the same forestay. One headsail shall then be set to windward on a spinnaker pole (SPL). See as well item 3.1.10.

**and**

Added new text to paragraph 4.1.3:

The point on the sheer line as defined for measuring Gmax, FBSB and FBBB shall be placed on the fair curve or straight line, which forms the sheer line of the hull from stem to transom.

**and**

Added new text to paragraph 4.2.3 under LP:

LP shall not be greater than  $0.65 * T_{max}$

**and**

Added new text to paragraph 4.2.3 under J:

If a headsail can be set on the boat on an inner forestay aft of the foremost forestay – whereto J is measured – the intersection point between the deck and the centre line of the inner forestay, extended if necessary, shall not be less than  $0.60 * J$  forward of the foreside of the mast, measured in the same manner as J.

**and**

Added new text to paragraph 4.5.3:

If the measurer's visual assessment of the Keel Factor (KF) gives a false image of the vertical centre of gravity (VCG), KF is to be determined by the TC. The owner is responsible for the measurer being given the correct details of the VCG of the keel. Any questions regarding determination of KF shall be referred to the DSA Chief Measurer.

### March 2005

According to the new Racing Rules of Sailing (RRS) 2005-2008, the DH Rule, paragraph 3.0, General Regulations was amended as follows:

According to item (d) of the RRS definition "Rule" the DH rule applies as class rules for all boats racing in regattas or classes organised for DH-boats.

### September 2004

Added new text to paragraph 4.2.3 under T<sub>max</sub> and LP:

T<sub>max</sub> shall not be taken as less than  $0.75 * ISP$  when calculating the time allowances.

LP shall not be taken as less than  $0.75 * J$  when calculating the time allowances.

**and**

Added new text to paragraph 4.2.4 under ISP:

If the boat has no spinnaker halyard, ISP shall be taken as  $0.75 * P$  when calculating the time allowances.

# Danish Handicap

---

## **June 2004**

Added new item 10 to paragraph 3.1:

10. Headsails shall be set with the luff fastened to the forestay.

At least 80 % of its luff length (Tmax) shall be fasten to the forstay either by means of minimum 4 evenly distributed hanks, headfoil or similar fastening methods. The only exception is that one of the two headsails mentioned in part 3.1.6 may be set flying.

Spinnakers shall be set flying, i.e. not fastened to a forestay.

Battens are not permitted in spinnakers.”